

Advantages & Draw backs of an Online Configuration

Heiko Schmidt
Head of Engineering
Business Unit Medium Speed
SBU Marine & Engines

MAN Diesel & Turbo SE



„Engineering the Future – since 1758“

2011

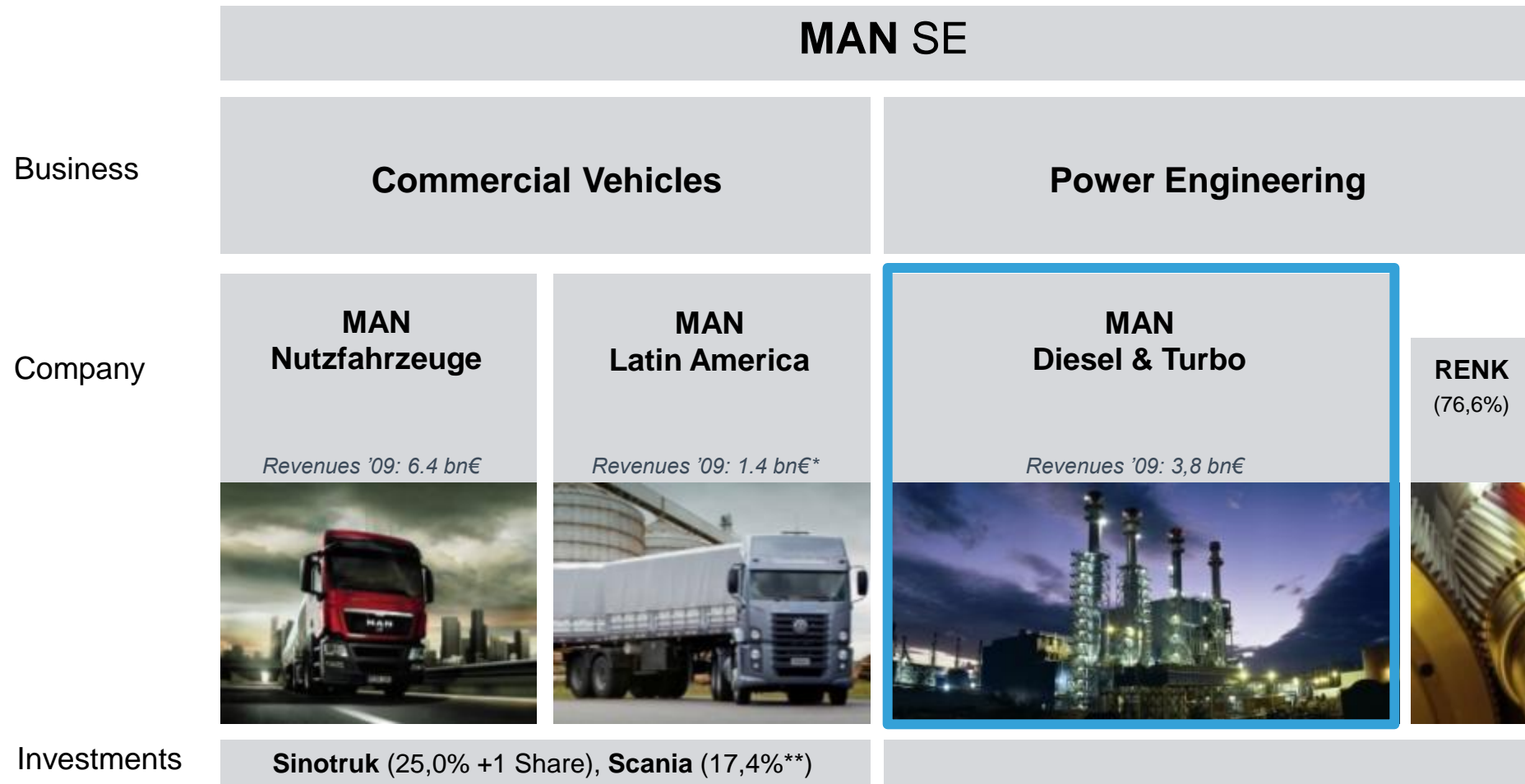

MAN Group 2009: 12.0 bn€ Revenues, 47,700 Employees

** April-December 2009*

*** Voting Rights*

Product Range - MAN Diesel & Turbo

by Strategic Business Unit



Engines & Marine Systems



Turbomachinery



Power Plants



After Sales



Areas of activity

Diesel Engine range from 450 kW to 87,000 kW

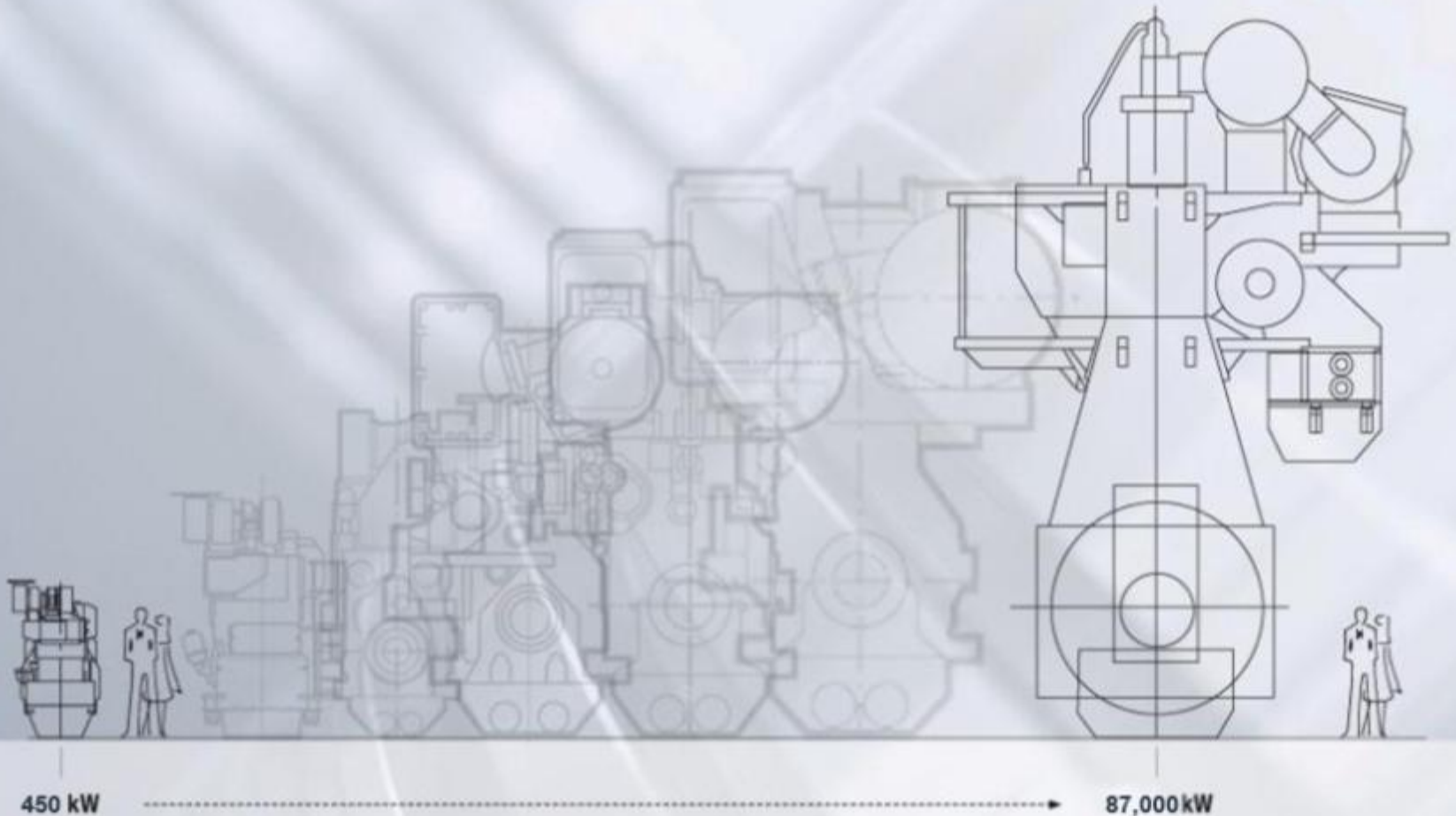

MAN Diesel Engine Viewer

Agenda



MAN Engine Viewer

- Functions and purpose

Viewer since 2003 (MDT)

- Assets and drawbacks

Viewer new generation (MDT/Cadenas)

- Assets and drawbacks

Viewer next generation

- Scope and demands



MAN Diesel Engine Viewer

Agenda



MAN Engine Viewer

- Functions and purpose

Viewer since 2003 (MDT)

- Assets and drawbacks

Viewer new generation (MDT/Cadenas)

- Assets and drawbacks

Viewer next generation

- Scope and demands



Products

Engines & Marine Systems



- 2-stroke and 4-stroke engines for marine applications
- Output range from 450 kW to 87,000 kW (Low Speed)
- Gensets from 450 kW to 11,200 kW
- Fuels: diesel, bio-fuels, heavy-fuel oil, gas/dual fuel
- Complete propulsion packages
- Axial and radial turbochargers for 2-stroke and 4-stroke engines, injection systems



Areas of activity

Marine Systems Engineering

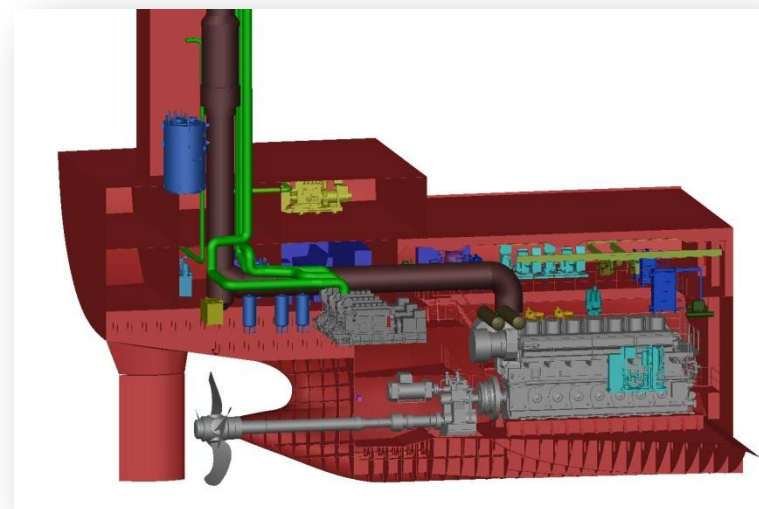
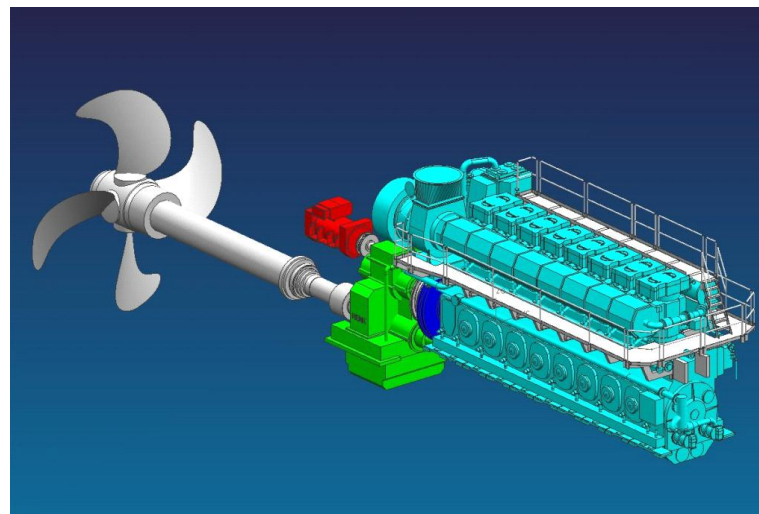
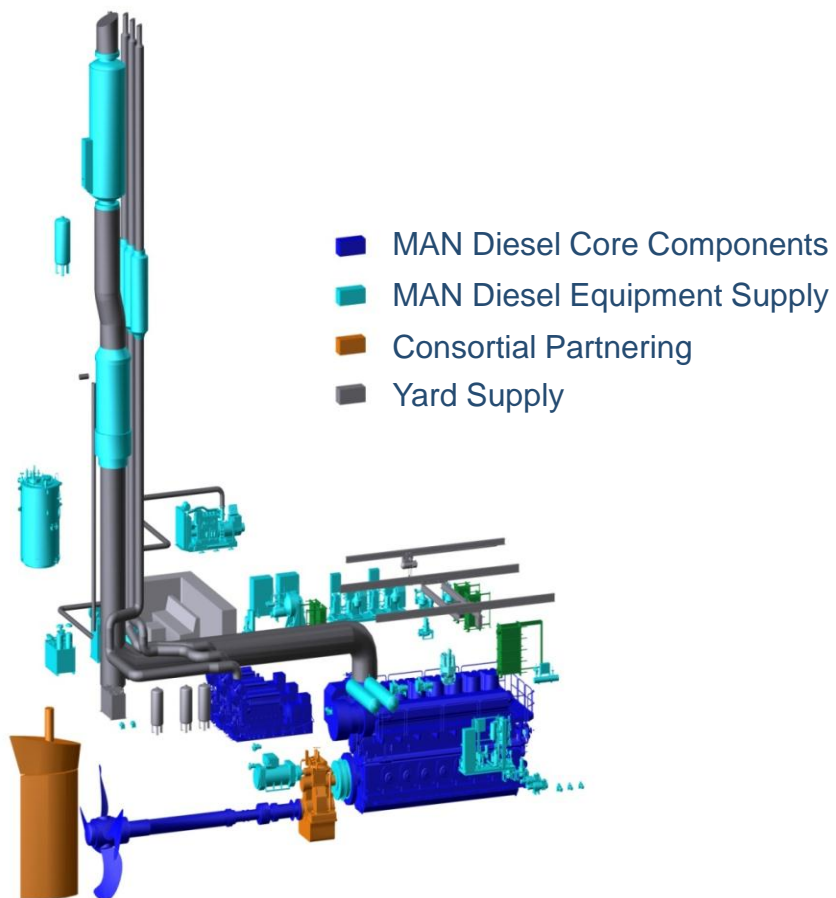

MAN Diesel Engine Viewer

MAN Diesel Engineering Service

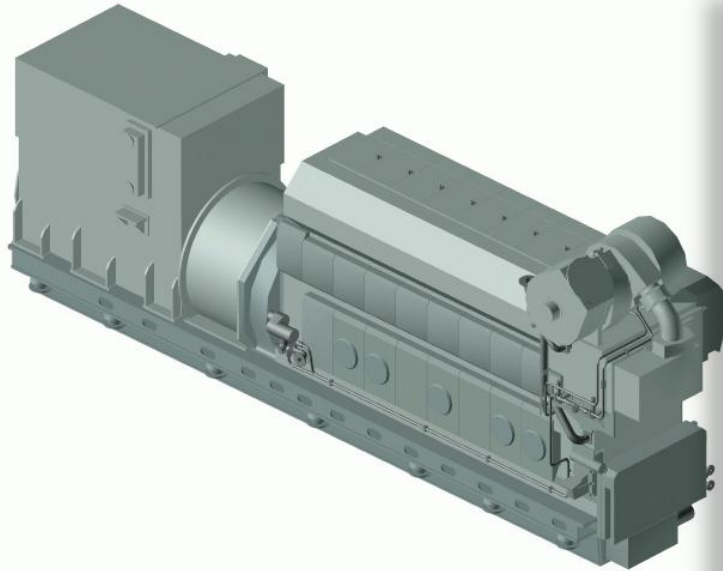

Yards and Ship designer ask for 3D light weight shape models for engines, gensets, propulsion trains and equipment needed for rapid prototype design of engine room arrangements

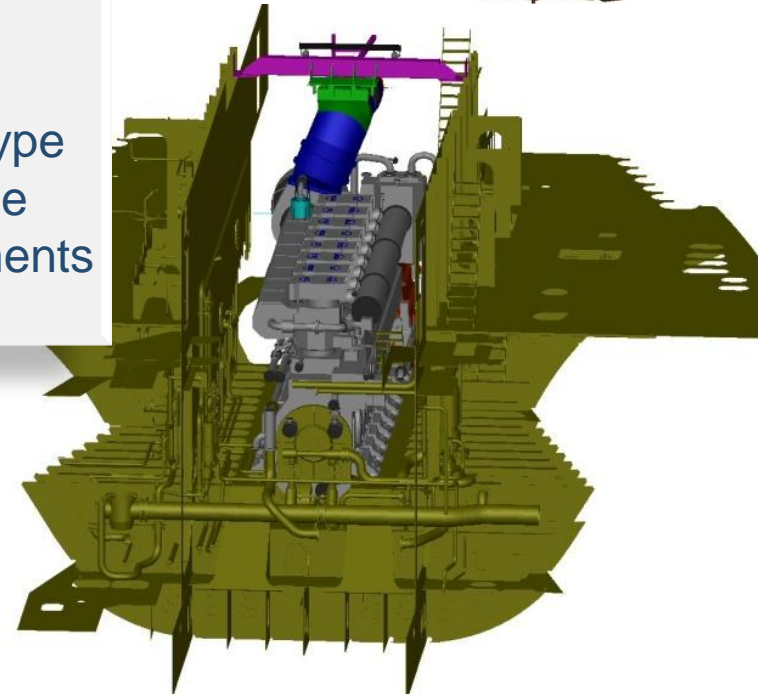
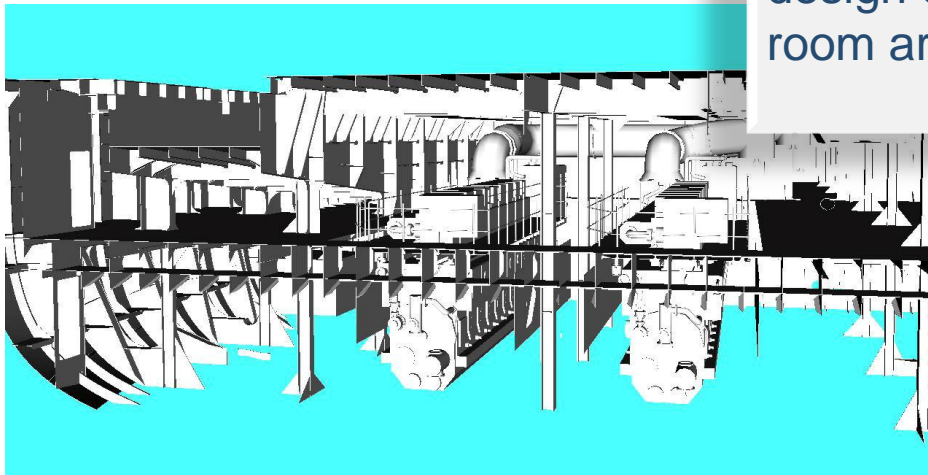
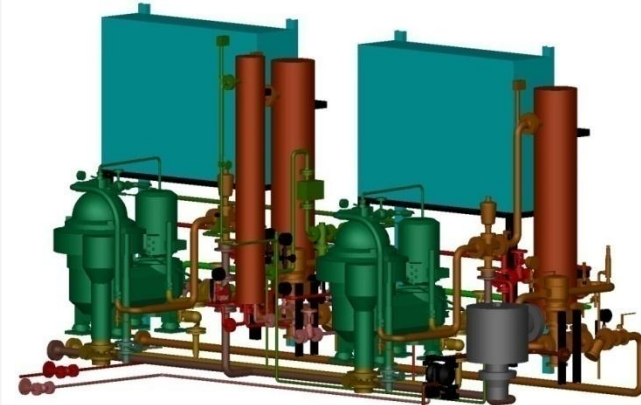

MAN Diesel Engine Viewer

Engine room study



- Arrangement: Study diesel-electric drive for a 1100TEU container vessel

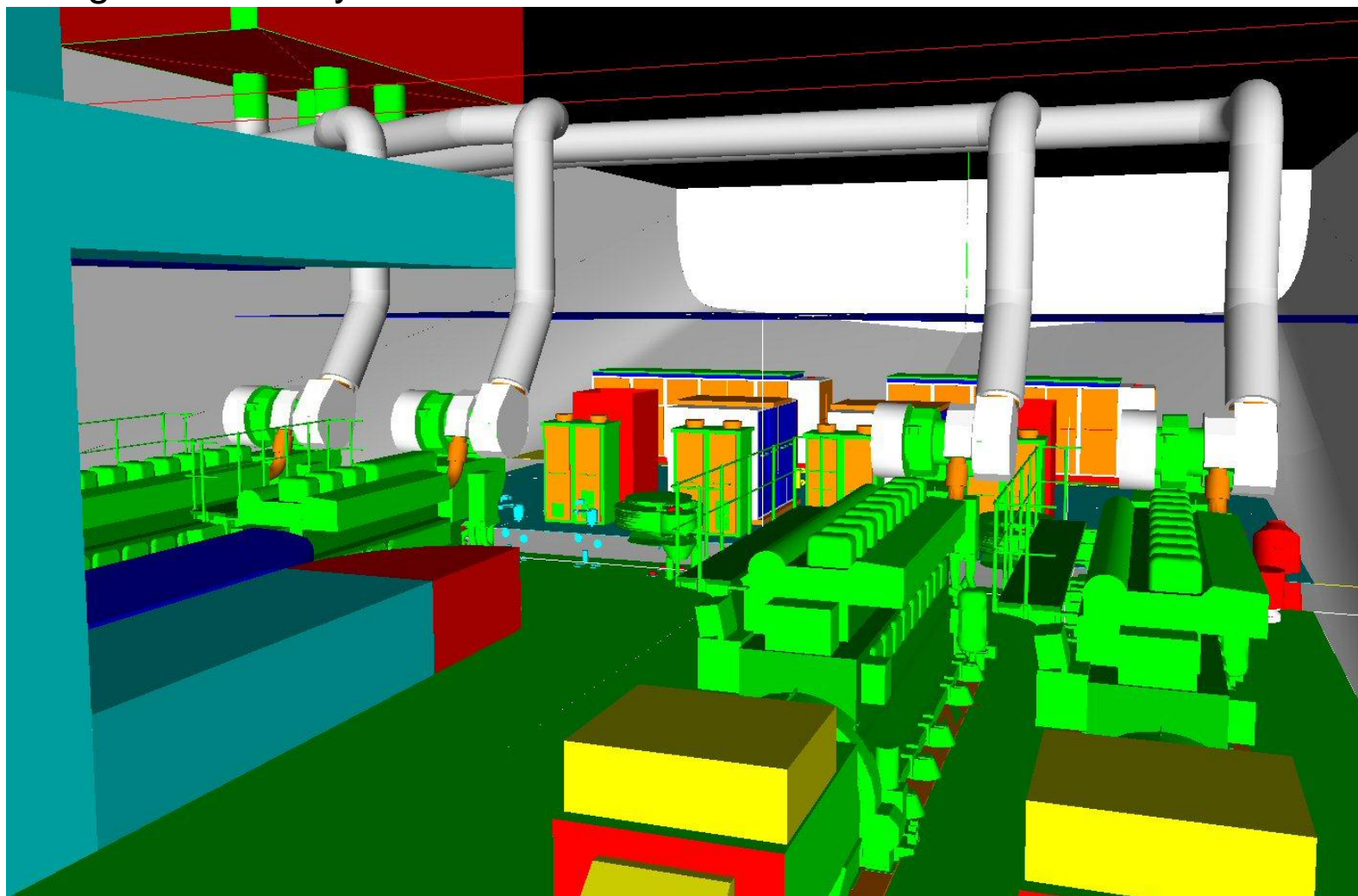

MAN Diesel Engine Viewer

MAN 3D Viewer family of MDT



Propulsion Viewer

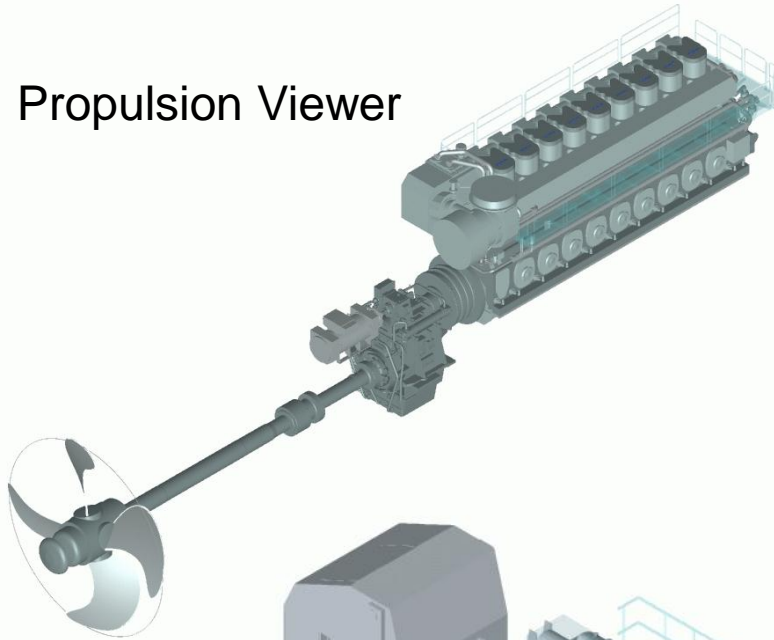

GenSet Viewer

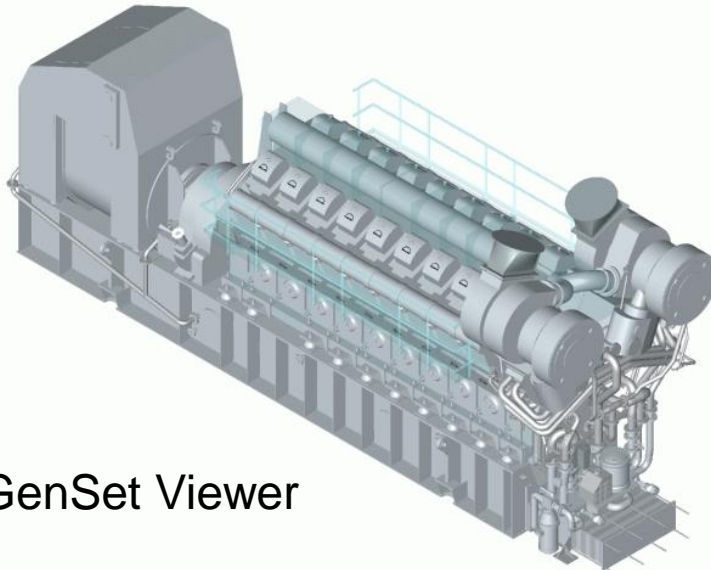

MAN Engine Viewer

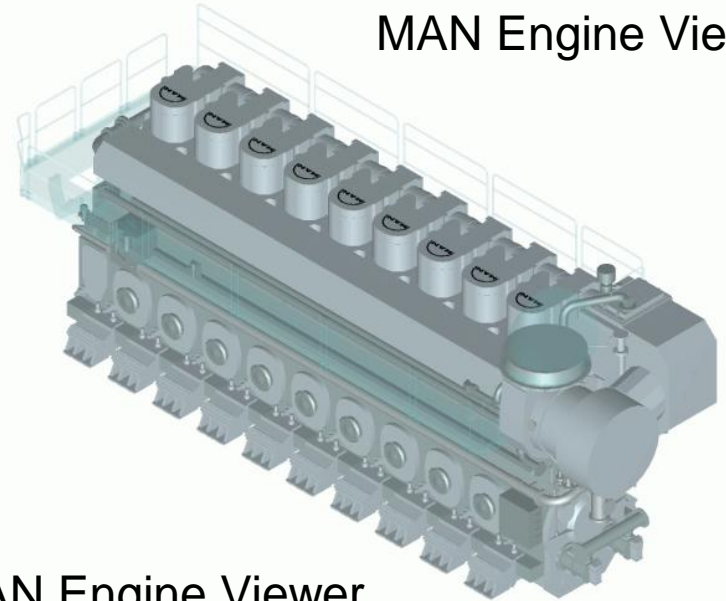

MAN Engine Viewer
via Cadenas

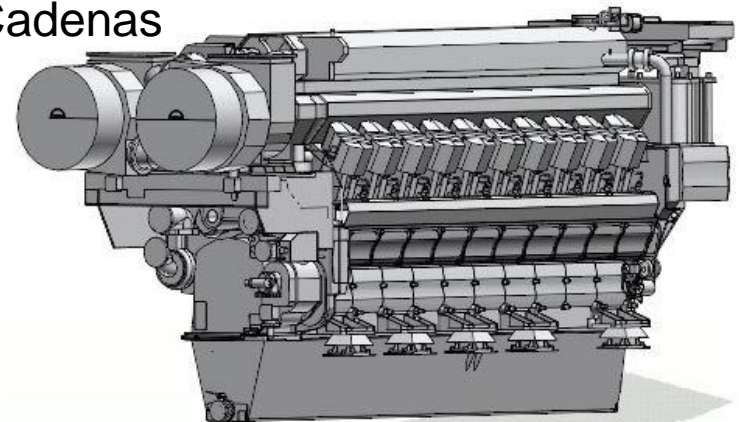

MAN Diesel Engine Viewer

Agenda



MAN Engine Viewer

- Functions and purpose

Viewer since 2003 (MDT)

- Assets and drawbacks

Viewer new generation (MDT/Cadenas)

- Assets and drawbacks

Viewer next generation

- Scope and demands



MAN Diesel Engine Viewer

Assets



Home
Project Tools
Service Support
Marketing & Sales
Projects
E-applications
Contact

Engine Viewer
v1.1.2

3D Show startconfig

Application mode

Propeller ▼

T.C. Arrangement 🔍

TCA 88 on CS ▼

Exhaust 🔍

Standard vertical ▼

Platform 🔍

Without platform ▼

Engine seating 🔍

Rigid mounting ▼

Power takeoff FE 🔍

Without output on FE ▼

Built on pumps 🔍

Cooling and lubrication pumps ▼

Iso views

Installation drawings

Dismantling area

Nozzle ports

Download

User: Josef Zeilmann

Contact other engines Configurations 18V48/60B ▼ Enter configuration

18V48/60B | 500 - 514 rpm | 21600 kW

Filename	Description	Size	Release
<input type="checkbox"/> 1174000-0828_dxf	Installation drawing with nozzle ports	2 MB	6/2005
<input type="checkbox"/> 1174000-0739_dxf	General installation drawing	305 kB	5/19/03
<input type="checkbox"/> 1174000-0735_dxf	Dismantling area	246 kB	9/9/03
pdf-Format			
<input type="checkbox"/> 1174000-0828_pdf	Installation drawing with nozzle ports	2 MB	6/2005
<input type="checkbox"/> 1174000-0739_pdf	General installation drawing	80 kB	5/19/03
<input type="checkbox"/> 1174000-0735_pdf	Dismantling area	96 kB	9/9/03

3D files all ▼

Filename	Description	Size	Release
<input type="checkbox"/> 18V48n-dgn	Basic engine model	387 kB	8/22/05
<input type="checkbox"/> 18V48m-dgn	Nozzles	40 kB	8/22/05
<input type="checkbox"/> 18V48a-dgn	Dismantling area	6 kB	10/17/03
<input type="checkbox"/> 18V48g-dgn	Gallery	136 kB	10/17/03

Filename	Description	Size	Release
<input type="checkbox"/> 18V48n-sat	Basic engine model	3 MB	8/22/05
<input type="checkbox"/> 18V48m-sat	Nozzles	109 kB	8/22/05
<input type="checkbox"/> 18V48a-sat	Dismantling area	8 kB	10/17/03
<input type="checkbox"/> 18V48g-sat	Gallery	1 MB	10/17/03

Filename	Description	Size	Release
<input type="checkbox"/> 18V48n-igs	Basic engine model	1 MB	8/22/05
<input type="checkbox"/> 18V48m-igs	Nozzles	65 kB	8/22/05
<input type="checkbox"/> 18V48a-igs	Dismantling area	4 kB	10/17/03
<input type="checkbox"/> 18V48g-igs	Gallery	135 kB	10/17/03

Filename	Description	Size	Release
<input type="checkbox"/> 18V48n-3ds	Basic engine model	1 MB	8/22/05

- First configurator on the market
- Self-explanatory application
- Fast viewing
- Low platform investment

Engine nozzle-information

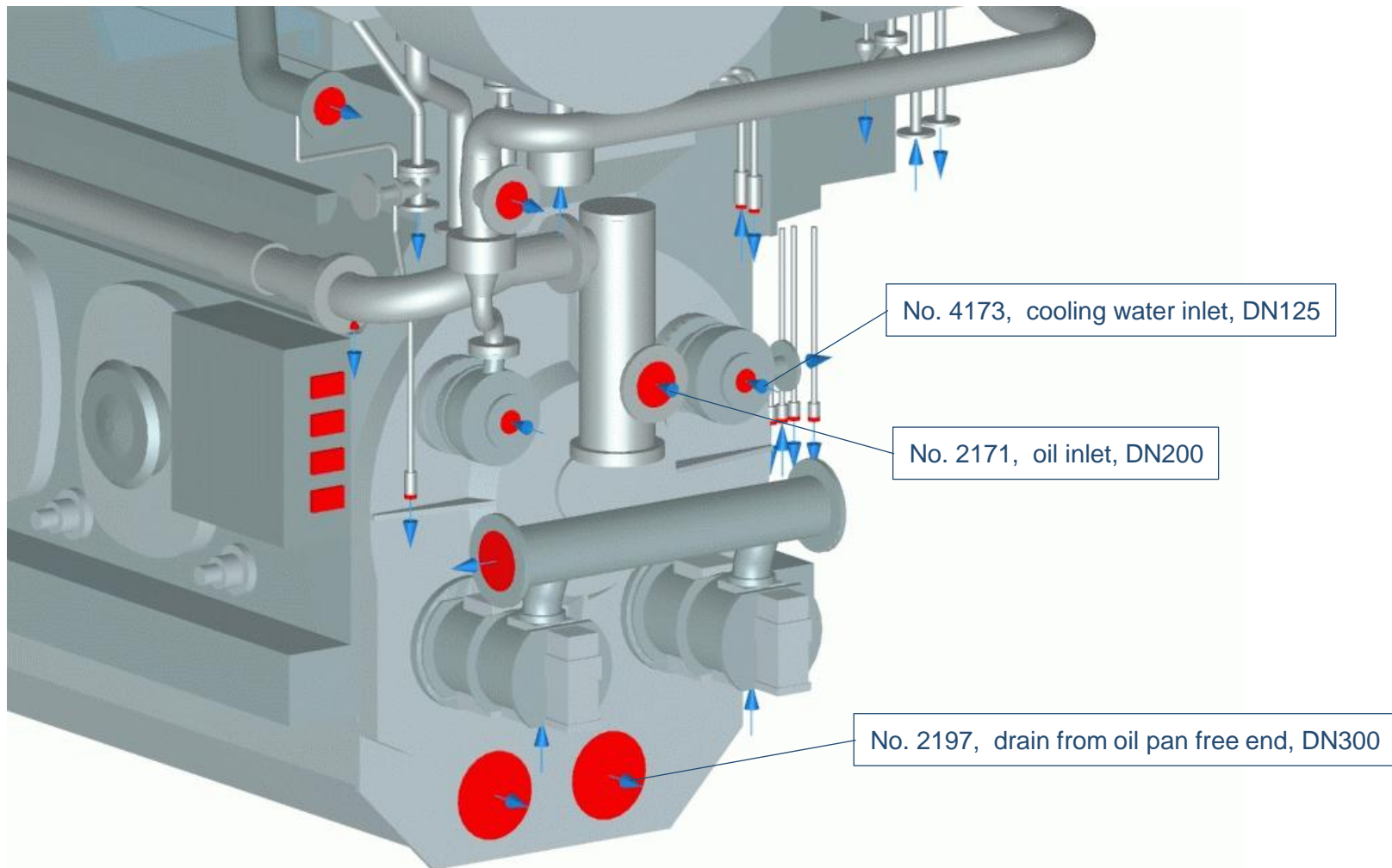

MAN Diesel Engine Viewer

Drawings



- Preliminary outline drawing

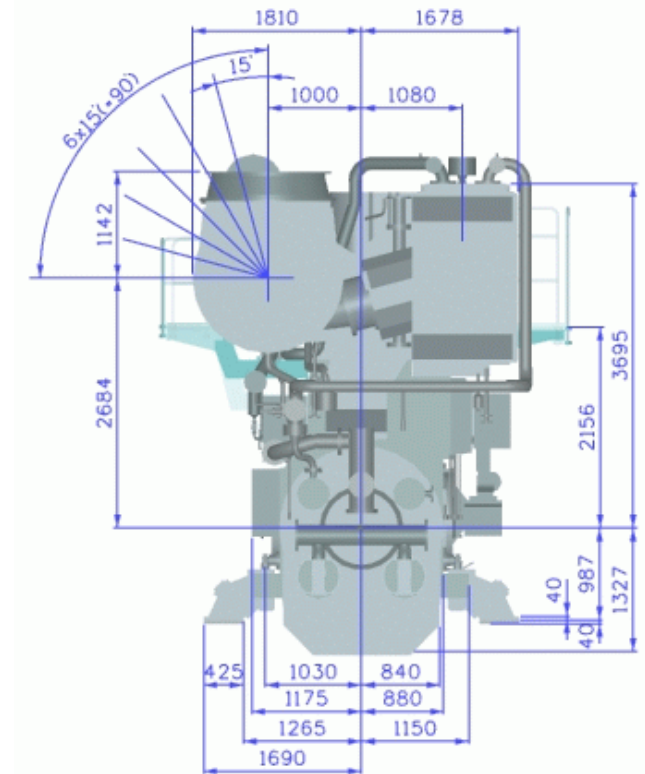
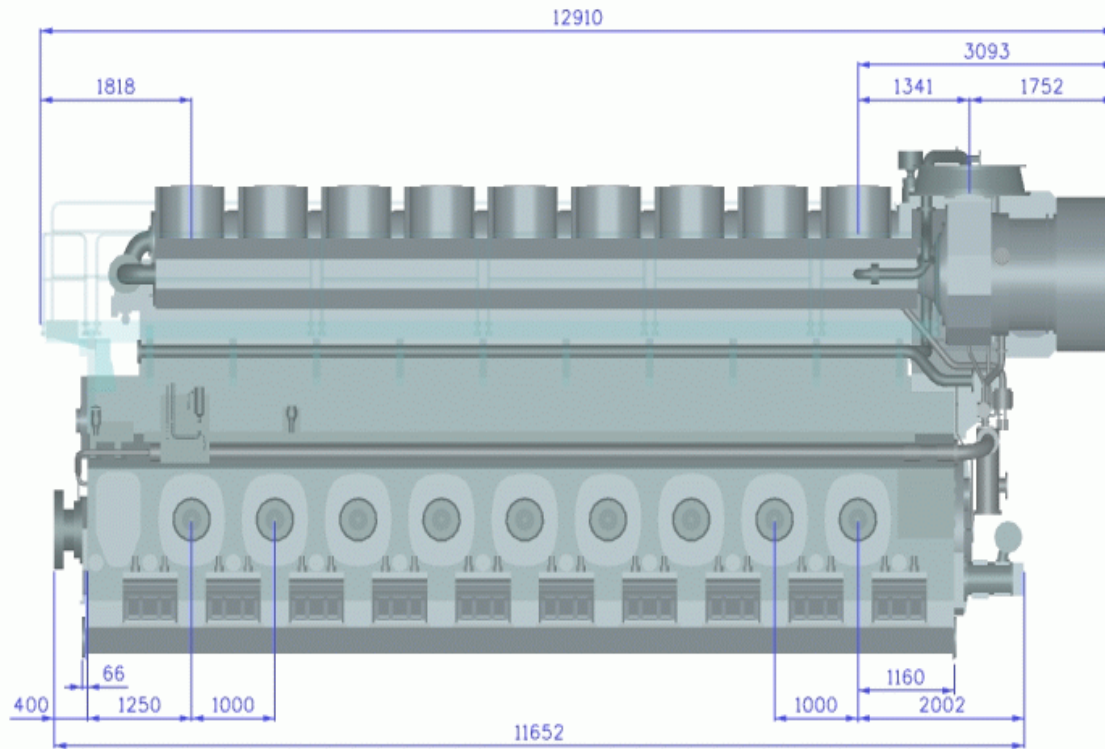

MAN Diesel Engine Viewer

Drawbacks



- Excessive efforts for modelling and pre configuration
- Selective predefined configs only
- Import problems for other CAD
- File size after conversion
- Only few neutral formats reliable
- No native formats for ship design
- No professional CAD format service

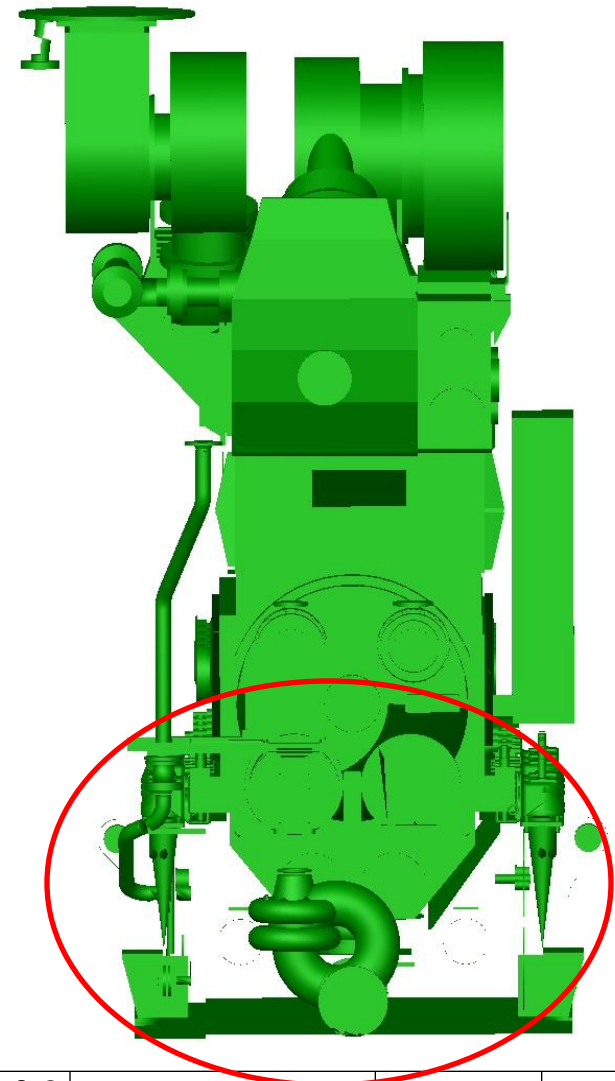
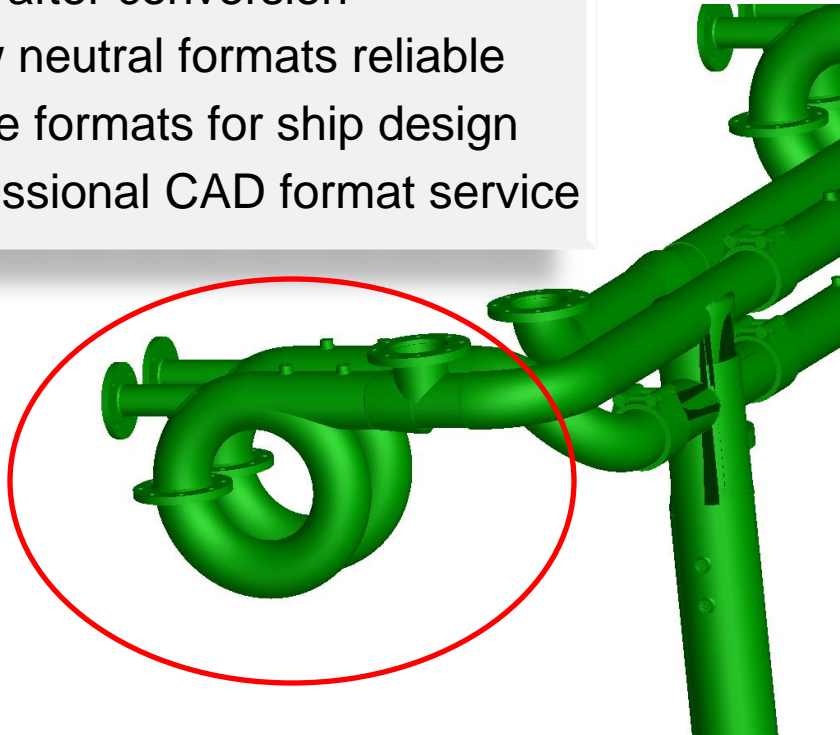

MAN Diesel Engine Viewer

Experience



Experience with neutral CAD formats

MAN Diesel & Turbo can only focus on a **small no of neutral export formats**

Model validation of converted CAD formats within **MAN IT Environment** not affordable

Experience regarding quality of conversion and import within customer environment **sporadically**

Customers demand

Full range of engine application portfolio for fast download (24/7)

Small size of 3D light shape models as native customer specific format

Validated and reliable 3D models for arrangement pre studies (self configuration) and detailed plant engineering (certified by supplier)

MAN Diesel Engine Viewer

Agenda



MAN Engine Viewer

- Functions and purpose

Viewer since 2003 (MDT)

- Assets and drawbacks

Viewer new generation (MDT/Cadenas)

- Assets and drawbacks

Viewer next generation

- Scope and demands



MAN Diesel Engine Viewer

MAN 3D Viewer with Cadenas technology



Online GUI with Cadenas PARTSolution – adopted to MDT specification



Products

US ? Help Search Feedback

AAAAQE | Logout | Copyright

Welcome CAD MODELS Settings

1.9 | powered by CADENAS | PARTSolutions

Preview

Symbols Search



- TC (Turbo charger): turbocharger on countercouplingside
turbocharger on counte
- TCT (Turbo charger type): TCA88
- EX (Exhaust): with transition socket

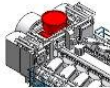

- EX1 (Transition socket): standard transition socket

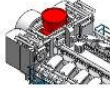

- GL (Platform): with platform



- S (Engine seating): beveled elastic mounting

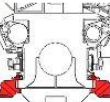

- PT (Power takeoff free end): without power takeoff

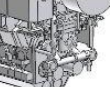

Preview for V5160DF-18-CCS-1-0-B-1-0-3-0
Caution: The pregenerated preview conforms to a sample part and may differ from the current CAD MODEL.

POWERED BY CAD | PART

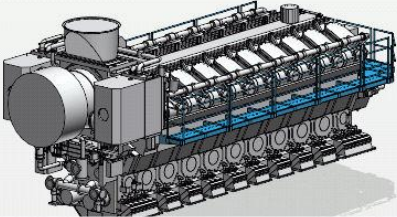

1552x918

Generated CAD MODELS

The generation of CAD models / PDF datasheets may take much time depending to the number of selected formats and system traffic. You may return later - the data will be supplied automatically.

Settings

You have currently 1 generated CAD MODEL.
Please note that expired CAD MODELS will be deleted automatically.

Generated CAD MODELS

	V5160DF-18-CCS-1-0-B-1-0-3-0	<input checked="" type="checkbox"/>	<input type="button" value="Download"/>	<input type="button" value="Delete"/>
---	------------------------------	-------------------------------------	---	---------------------------------------

Legend

Not generated

MAN Diesel Engine Viewer

MDT 3D Engine Viewer – Partsolution / Cadenas



- All configuration variants ready for download
- Reasonable effort for modelling
- No MAN effort for pre configuration
- Almost all neutral formats available
- Native formats for shipyards CAD
- Compressed file size in CAD
- Professional CAD format service (Cadenas)

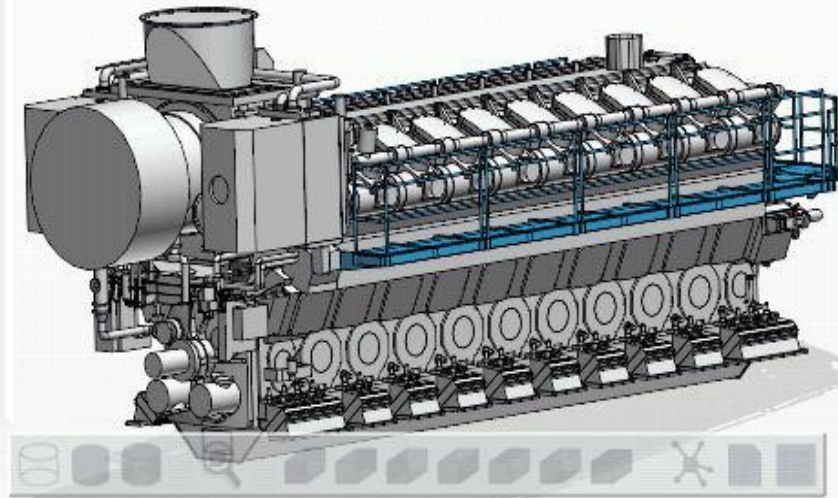

⤴ CAD MODEL for download

2D 3D

Neutral

IGES
JT
ParasolidText V15
SATV4.0
STEPAP214a
STL
VRML >= V1.0

Native

Aveva PDMS / Marine
Catia IUAV4
Catia >= V5 R8
Nupas / Cadmatic
Tribon M3
Unigraphics >= NX3

2D 3D

Neutral

BMP (2D View)
DWG >= V14
DXFV12
JPEG (2D View)

⤴ Send CAD MODEL via e-mail

MAN Diesel Engine Viewer

MDT 3D Engine Viewer Partsolution / Cadenas



Drawbacks

- Long run time for online conversion
- GUI for CAD professionals
- Too complex for quick selection
- Extended requirements for server performance
- Modelling in Cadenas system only

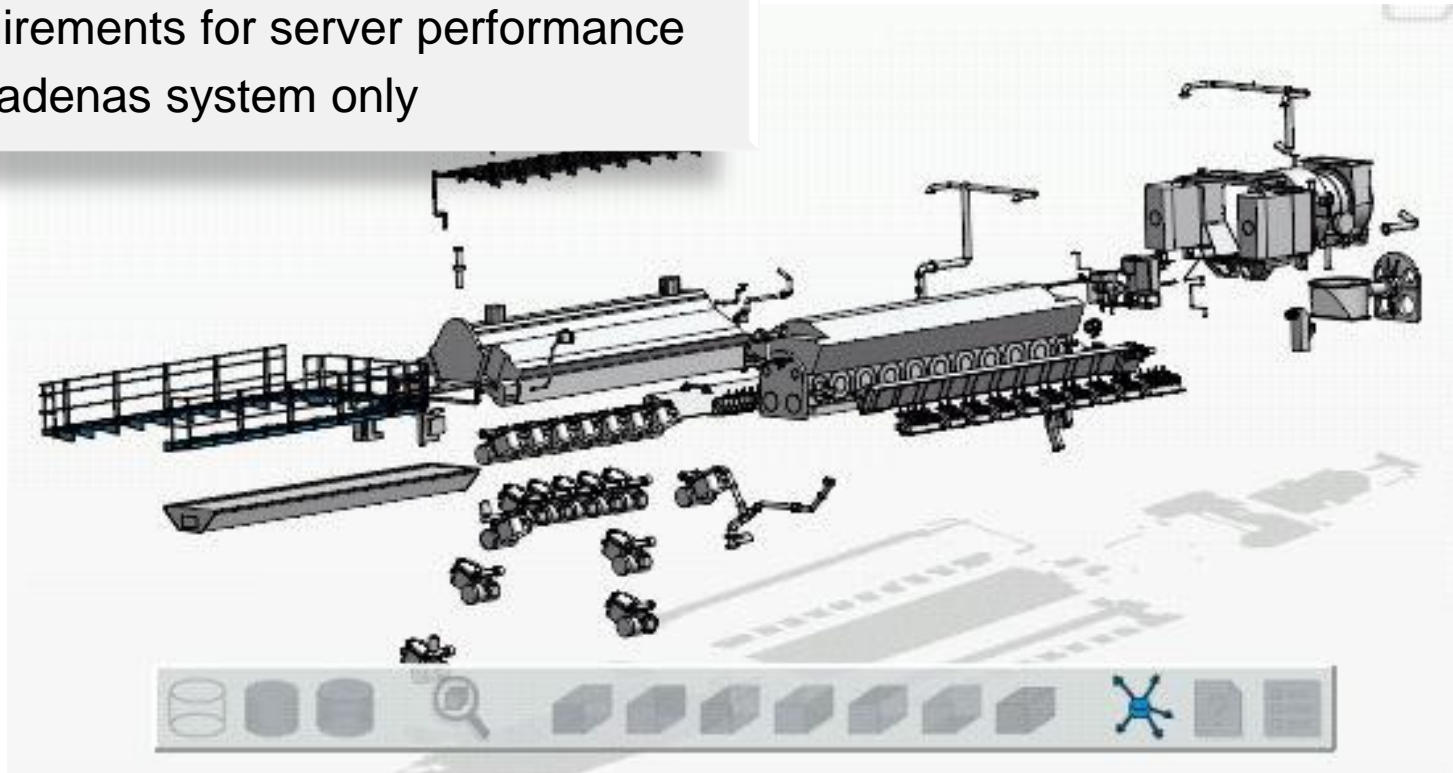

MAN Diesel Engine Viewer

MDT 3D Engine Viewer Partsolution/Cadenas



How to operate ?
(Online presentation)

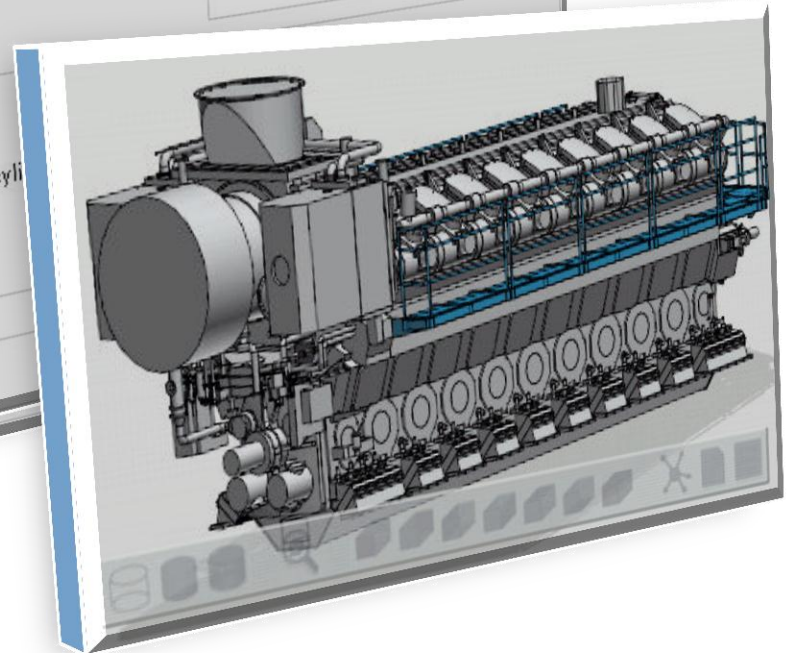
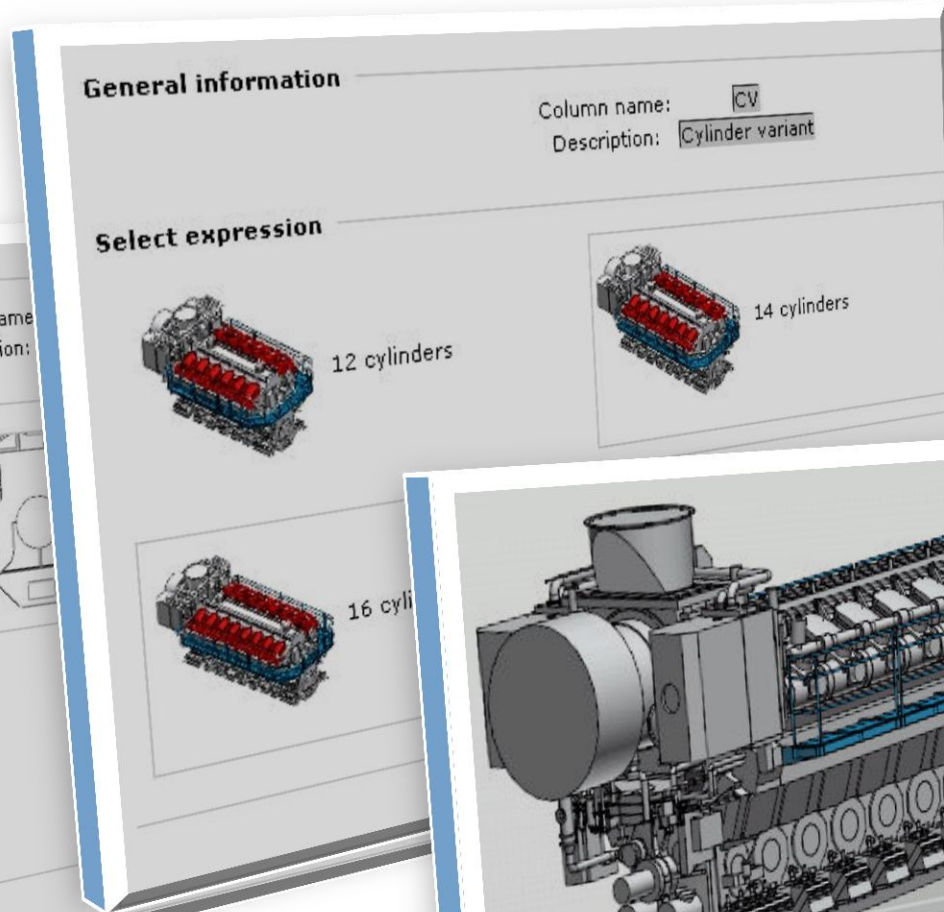
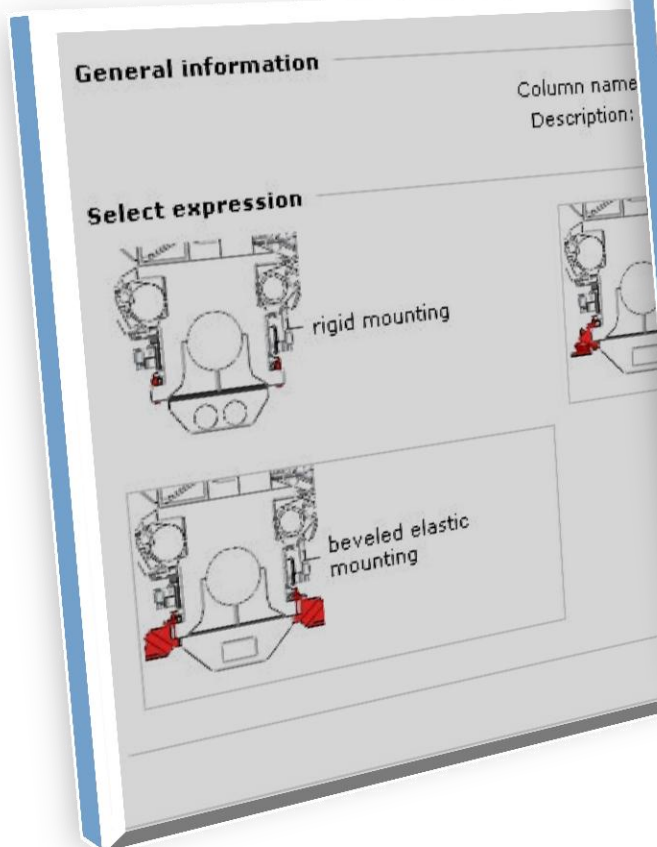

MAN Diesel Engine Viewer

3D Format service via Cadenas



MAN CAD-System Pro/E

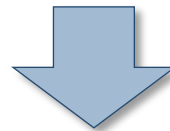
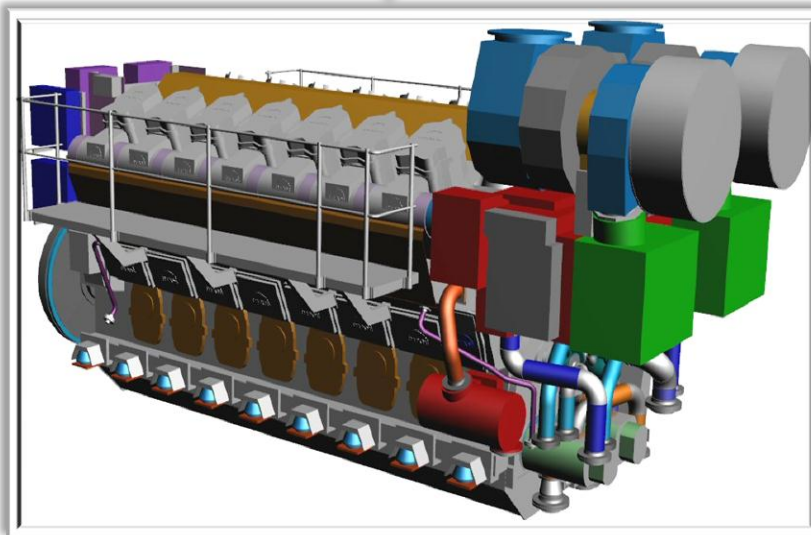
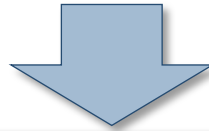

Drawing export
DWG / DXF

Neutral 3D formats

STEP AP214

ACIS SAT 4.0

IGES

VRML

STL

3D-PDF

JT

Native 3D formats

Tribon

Unigraphics

Catia

PDMS

Autocad

Cadmatic

Intergraph

Assets neutral formats:

- Direct model conversion from own CAD system
- Usable for different purposes
- Easy viewing

Assets native formats:

- Compact file sizes
- Tested interfaces
- Full functionality in target CAD system

MAN Diesel Engine Viewer

Import experience in shipyards CAD systems

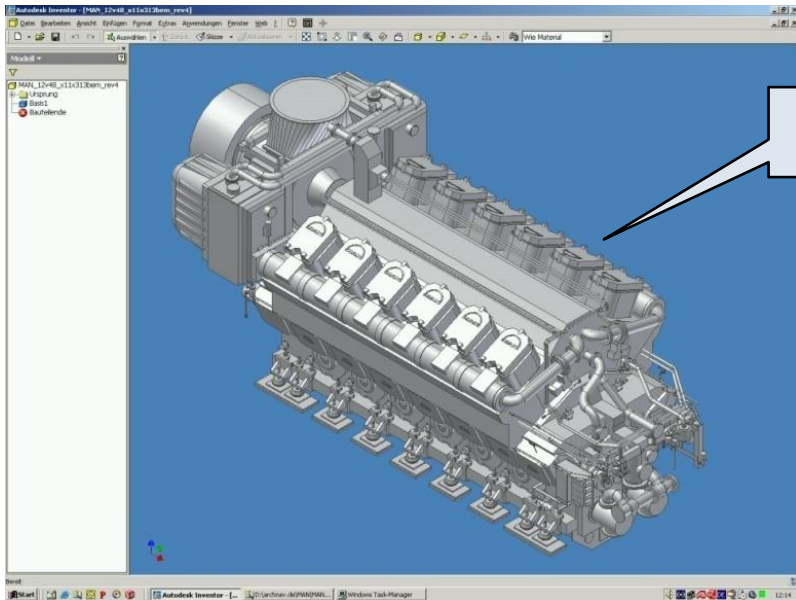

Import in
Autocad

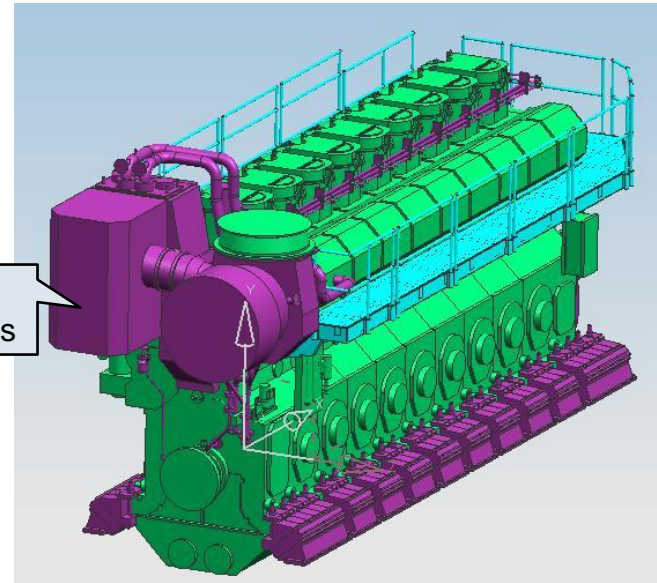

Import in
Unigraphics

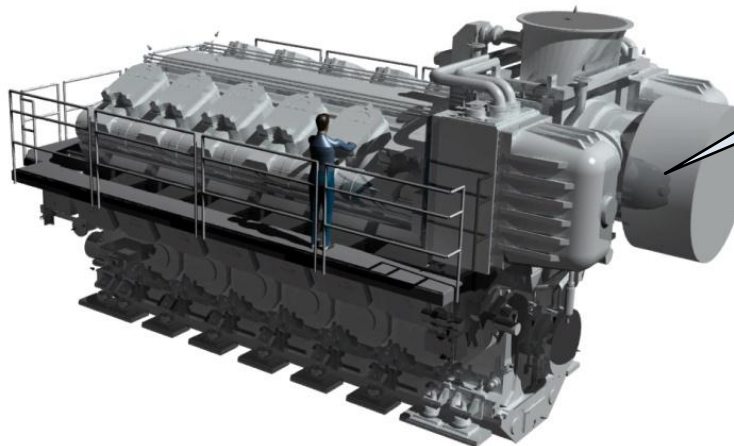

Import n.
CATIA V5

Import in
PDMS

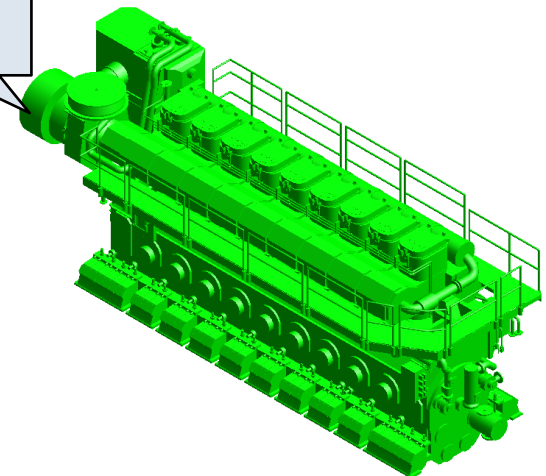

MAN Diesel Engine Viewer

Agenda



MAN Engine Viewer

- Functions and purpose

Viewer since 2003 (MDT)

- Assets and drawbacks

Viewer new generation (MDT/Cadenas)

- Assets and drawbacks

Viewer next generation

- Scope and demands



MAN Diesel Engine Viewer

Difference Standard design and Order design



Project handled with: FSG Germany

Standard configuration for prototyping and arrangement studies:

- Selection and download from Online MAN Engine Viewer by Yard

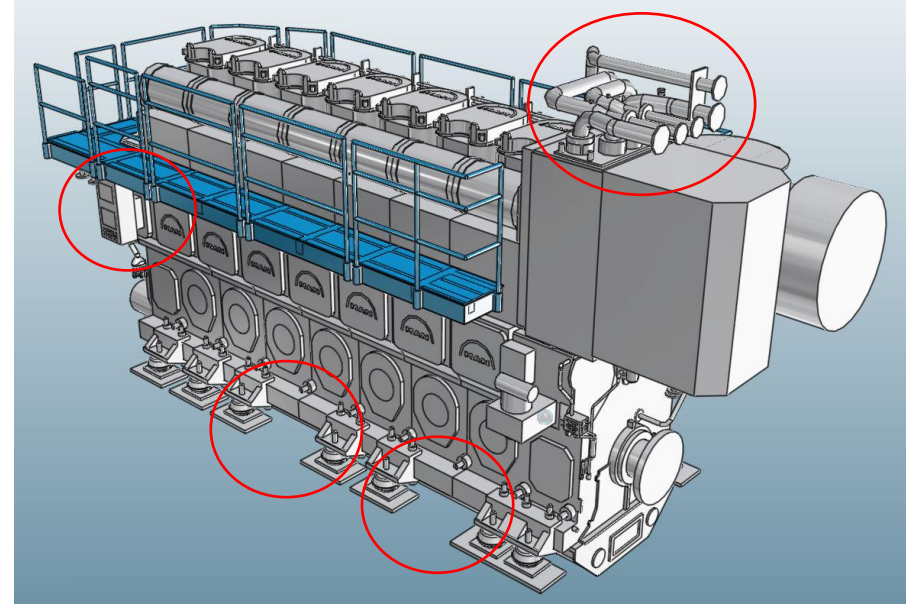
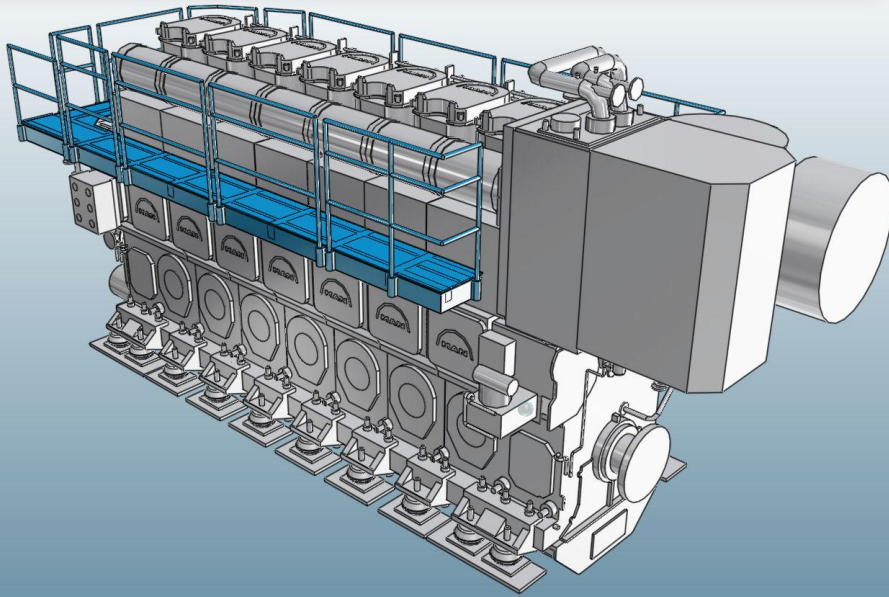

Order specific design for detailed engine room arrangement:

- Selected Engine Viewer model adapted by MAN engineering service to order specific requirements

MAN Diesel Engine Viewer

Difference Standard design and Order design



Project handled with: Daewoo Korea

Standard configuration for prototyping and arrangement studies:

- Selection and download from Online MAN Engine Viewer by Yard

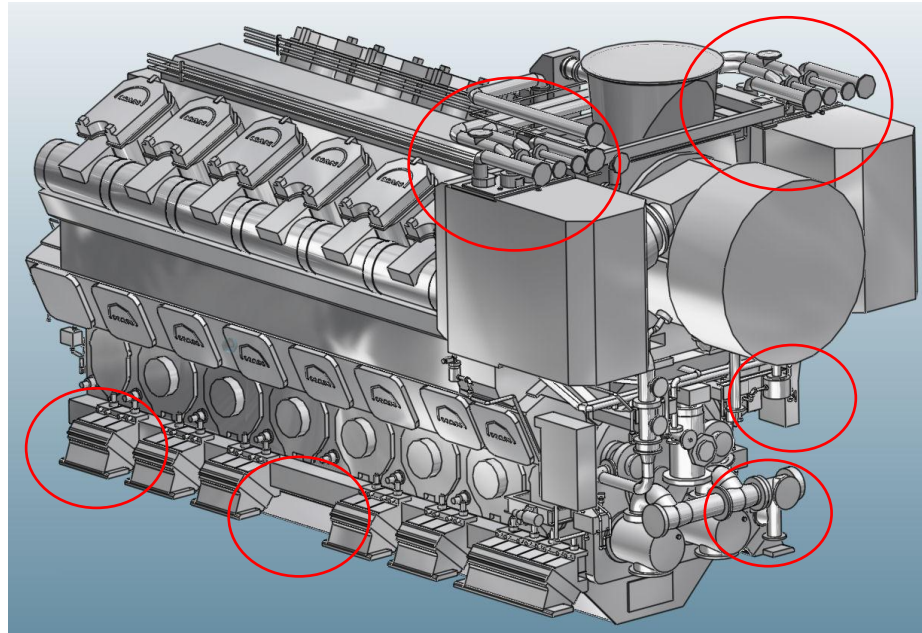
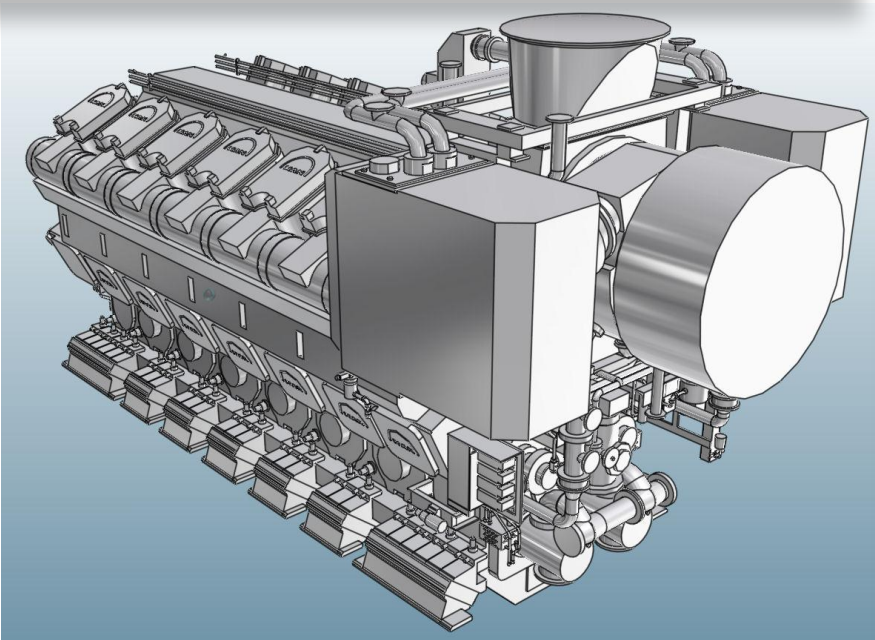

Order specific design for detailed engine room arrangement:

- Selected Engine Viewer model adapted by MAN engineering service to order specific requirements

MAN Diesel Engine Viewer

Workflow CAD data transfer

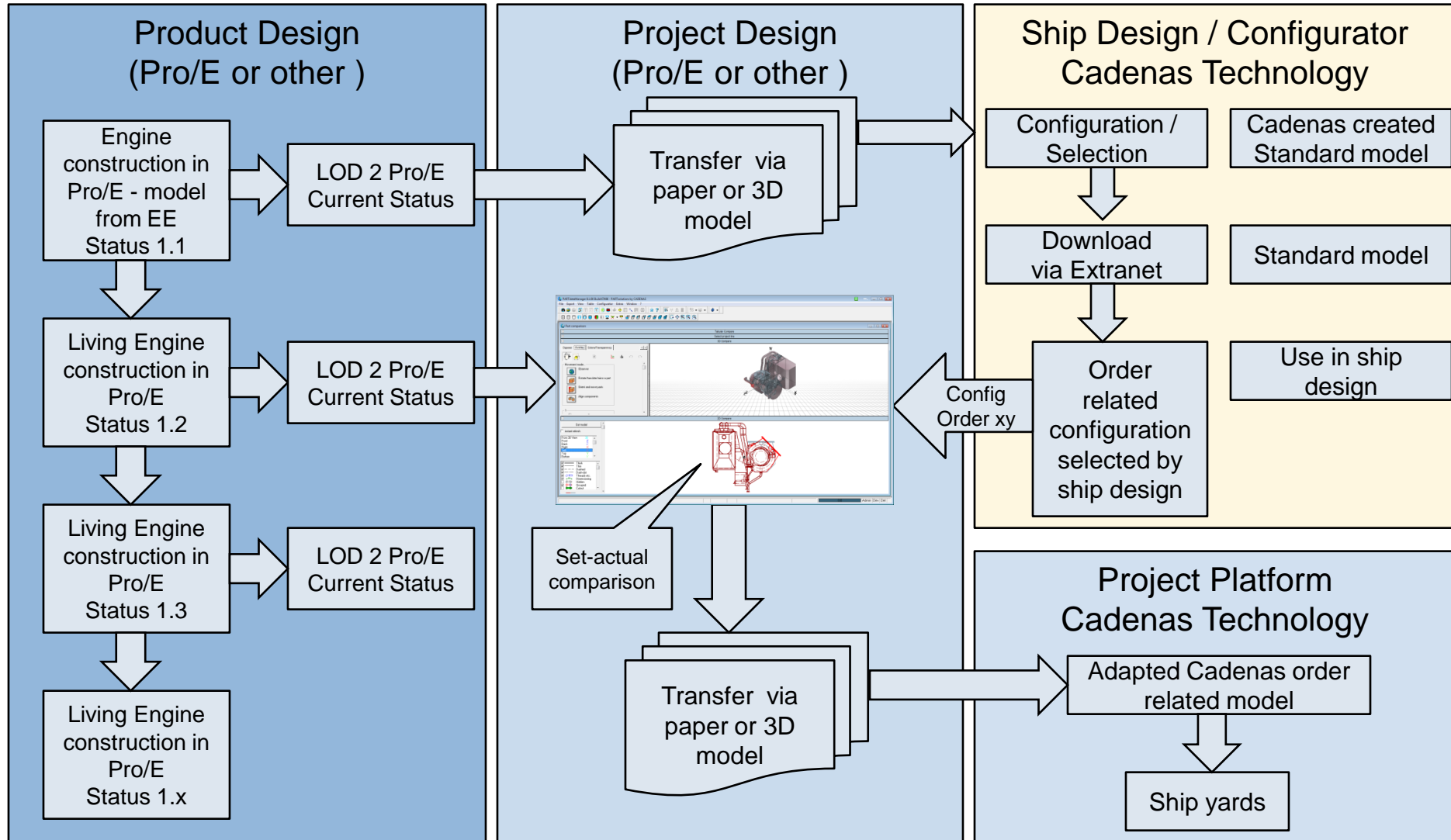

MAN Diesel Engine Viewer

Models of the future

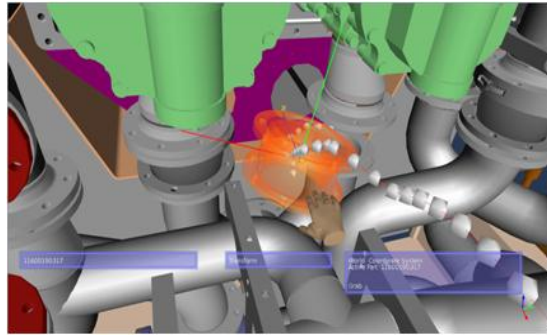

Virtual reality

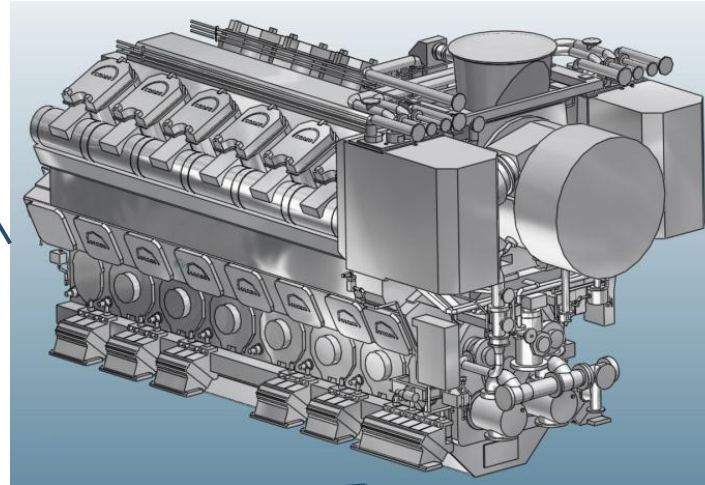

Engine-specific data:
Material information
Safety instructions
Classification regulations
Maintenance regulations
Training

Augmented reality



Ergonomic studies

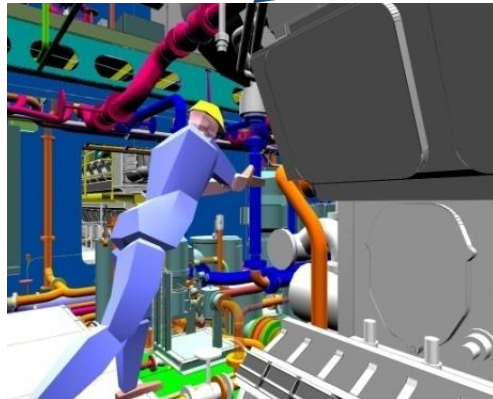

Removal simulation

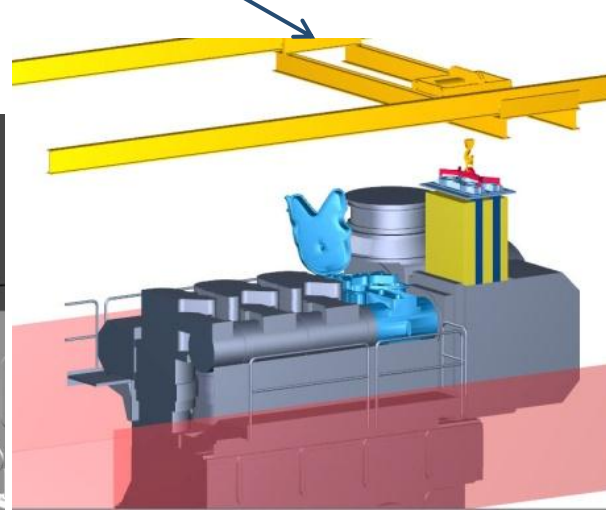

Work cards

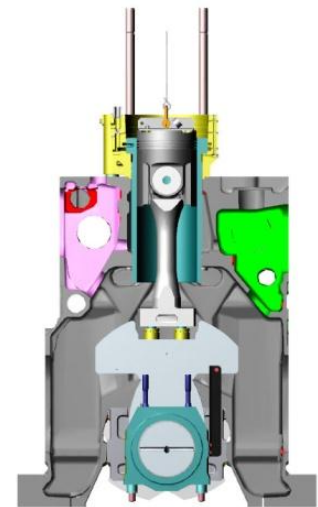

MAN Diesel Engine Viewer



MAN Diesel
powering the world